

# CASCADA FRESH WATER HEAT EXCHANGER



The **Cascada Fresh Water Heat Exchanger** is at the forefront of heat exchange products, ensuring high domestic hot water quality, always at the desired temperature, while it maintains significantly high efficiency. In addition, its unique design is such that it removes the risk of scale build-up.

System operation can be fully automated via PLC and real-time display is provided via touch screen or PC.

This product series could be implemented in various applications as in hotels, industries, hospitals and residences with increased water demand.



## PRODUCT MODELS

MODEL	CASCADA HE FW-CF 1/2	CASCADA HE FW-CF 1/3	CASCADA HE FW-CF 2/2	CASCADA HE FW-CF 2/3	CASCADA HE FW-CF 3/3
Nominal flow rate (m <sup>3</sup> /h)	2	3	4	6	9
Nominal Useful Power (kW)*	70	105	140	210	315
Primary Circuit Connections	1 1/2''	2''	1 1/2''	2''	2''
Secondary Circuit Connections	1''	1 1/2''	1''	1 1/2''	1 1/2''
Height (mm) (LEATHER)	650	650	1250	1250	1830
Height (mm) (INOX)	730	730	1300	1300	1900
Diameter (mm)	810	810	810	810	810
Weight(kg) (LEATHER)	41	49	74	90	173
Weight (kg) (INOX)	62	70	106	122	217
*Primary circuit temperature range: 60-55oC, Secondary circuit temperature range: 20-50oC AVAILABLE WITH INOX OR LEATHER COVER					

It is possible to design and implement a solution that includes a combination of the above autonomous systems, in order to meet demanding Domestic Hot Water requirements.

TECHNICAL SPECIFICATIONS	
<b>Heat exchanger type</b>	Counter flow, Corrugated
<b>Heat exchanger material</b>	INOX 316L
<b>Welding type</b>	Automatic circular welding
<b>Protection</b>	Inactivation coating
<b>Primary circuit nominal operating pressure</b>	3 bar
<b>Primary circuit maximum operating pressure</b>	6 bar
<b>Secondary circuit nominal operating pressure</b>	6 bar
<b>Secondary circuit maximum operating pressure</b>	12 bar
<b>Maximum operating temperature</b>	95°C
<b>Insulation</b>	Polyurethane foam (thickness: 80 mm, density: 45 kg/m <sup>3</sup> )
<b>Outer casing material</b>	INOX 304/PVC leather

## QUALITY CHARACTERISTICS

QUALITY CHARACTERISTIC	BENEFIT
<b>In Line</b> heating of domestic hot water through stored energy in buffer tanks	<i>It prevents the incubation of Legionella bacteria Maximizes the lifetime of the installation</i>
<b>Relatively low temperature difference</b> between primary and secondary circuit (max 5°C)	<i>Low charging temperatures Low operating cost</i>
Design based in <b>patent</b>	<i>High energy efficiency Constant supply of water at the desired temperature Minimum pressure drop in the water supply</i>
<b>High density polyurethane insulation</b>	<i>Negligible thermal losses during operation</i>
<b>Outer casing made of 304 stainless steel.</b>	<i>Potential of outdoor installation</i>
<b>Full compatibility</b> with existing hot water production and heating systems	<i>Utilization of existing equipment and systems</i>
<b>Simultaneous management of different working mediums</b> in terms of quality, pressure and supply	<i>Use of common thermal reservoir and energy sources for several different working mediums</i>
<b>Avoiding scale build-up</b> due to the innovative design	<i>Long lifecycle of the heat exchanger Stable and reliable operation</i>
<b>Reverse flow cleaning</b>	<i>Easy and quick cleaning</i>
<b>Small size and ergonomic design</b>	<i>Easy installation and space saving in engine rooms</i>

# PIPING AND INSTRUMENTATION DIAGRAMS (PIDs) AND 3D CONNECTION ILLUSTRATIONS

To facilitate the installation design of the Cascada fresh water heat exchanger, below you can find the PID as well as the 3d connection illustration for each heat exchanger model.

## CASCADA HE FW-CF 1/2 & CASCADA HE FW-CF 1/3

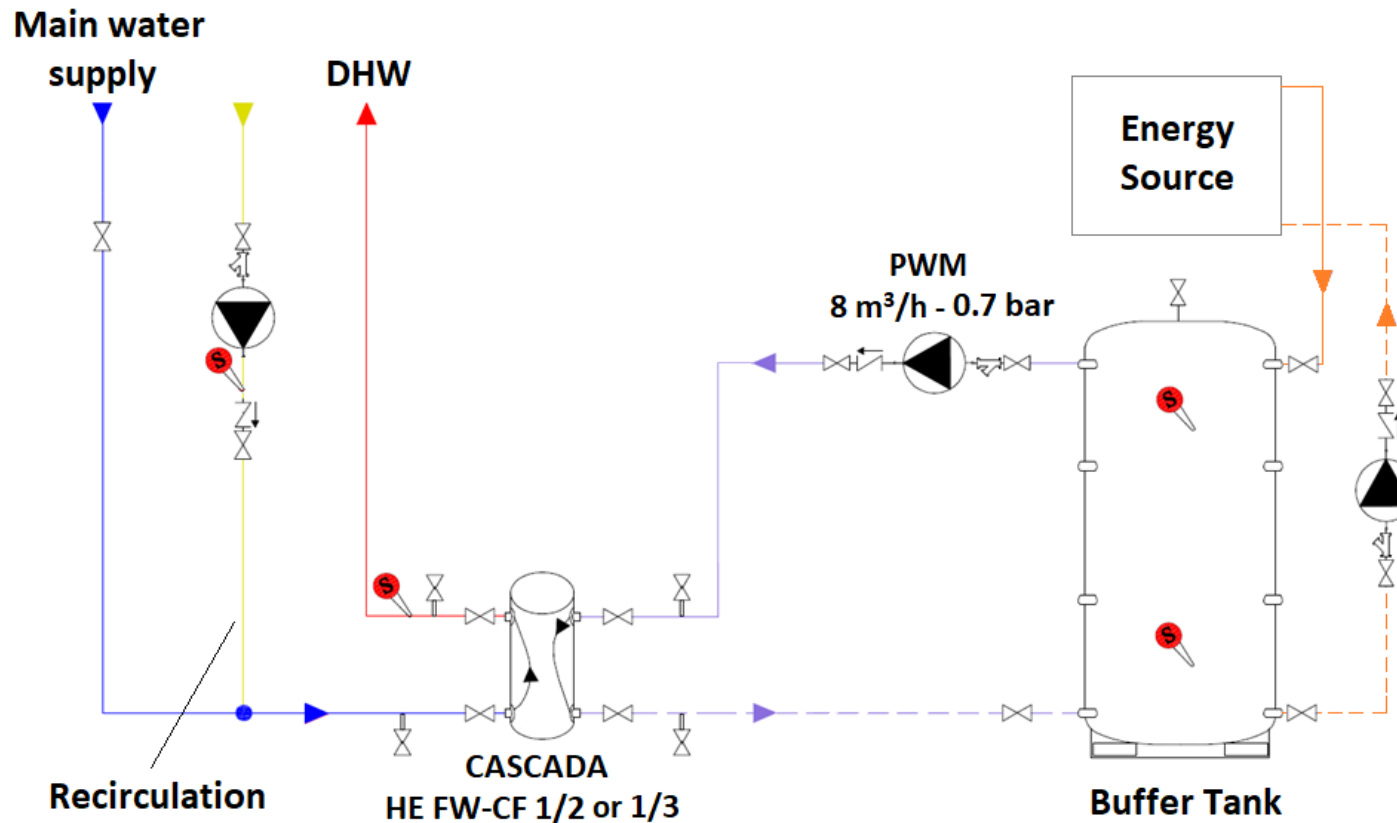



# CASCADA HE FW-CF 2/2, 2/3 or 2/4.5

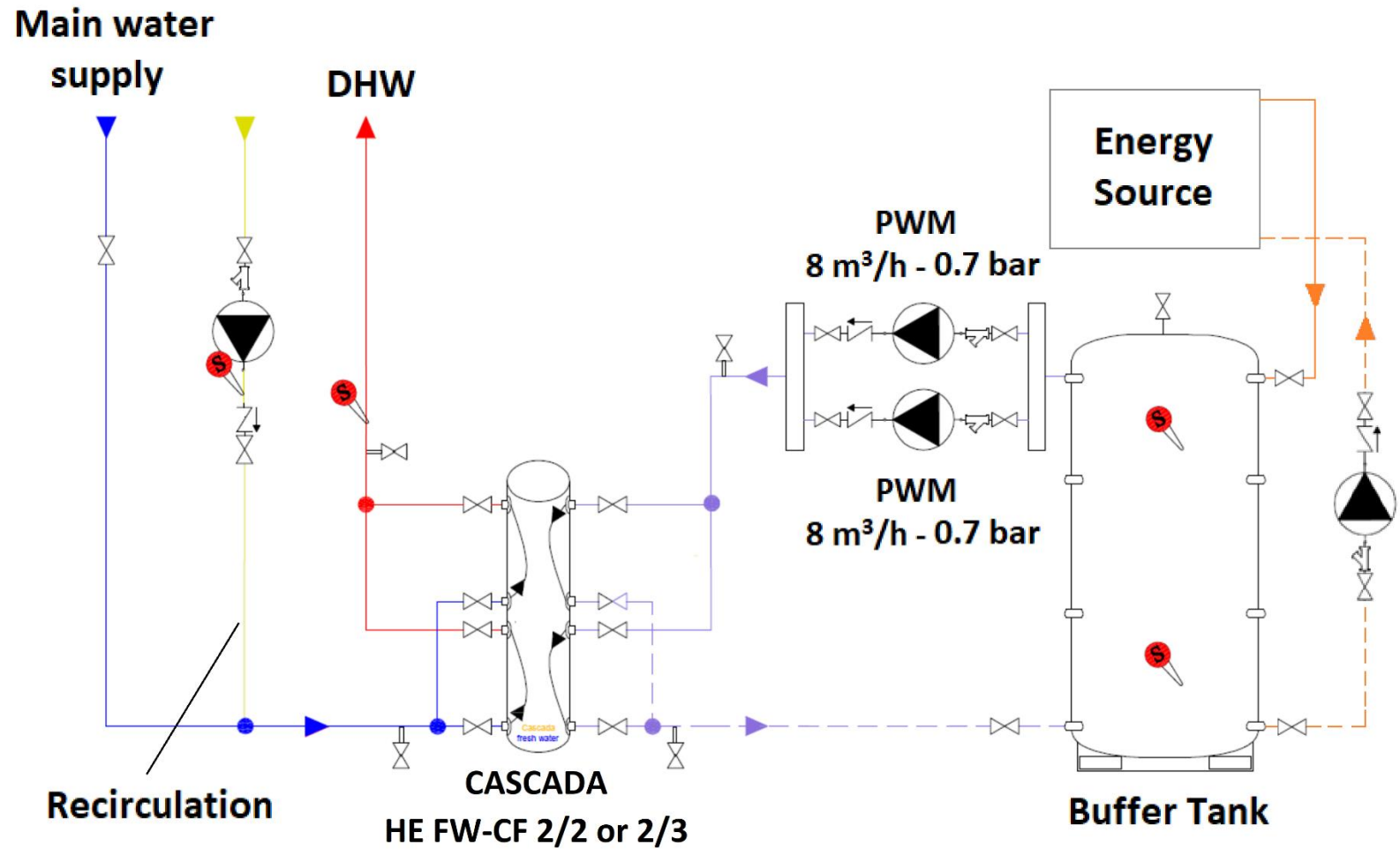

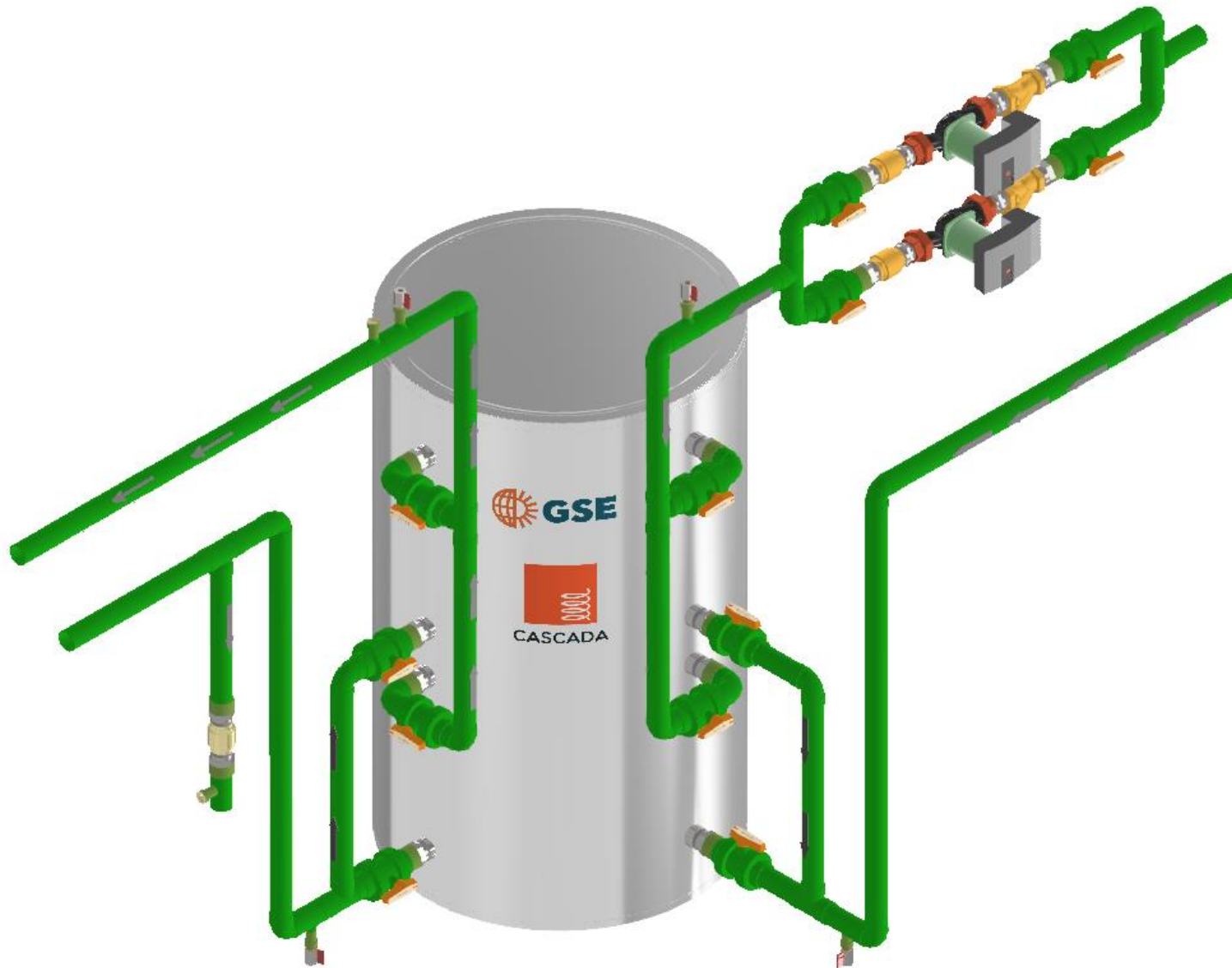

# CASCADA HE FW-CF 3/3 or 3/4

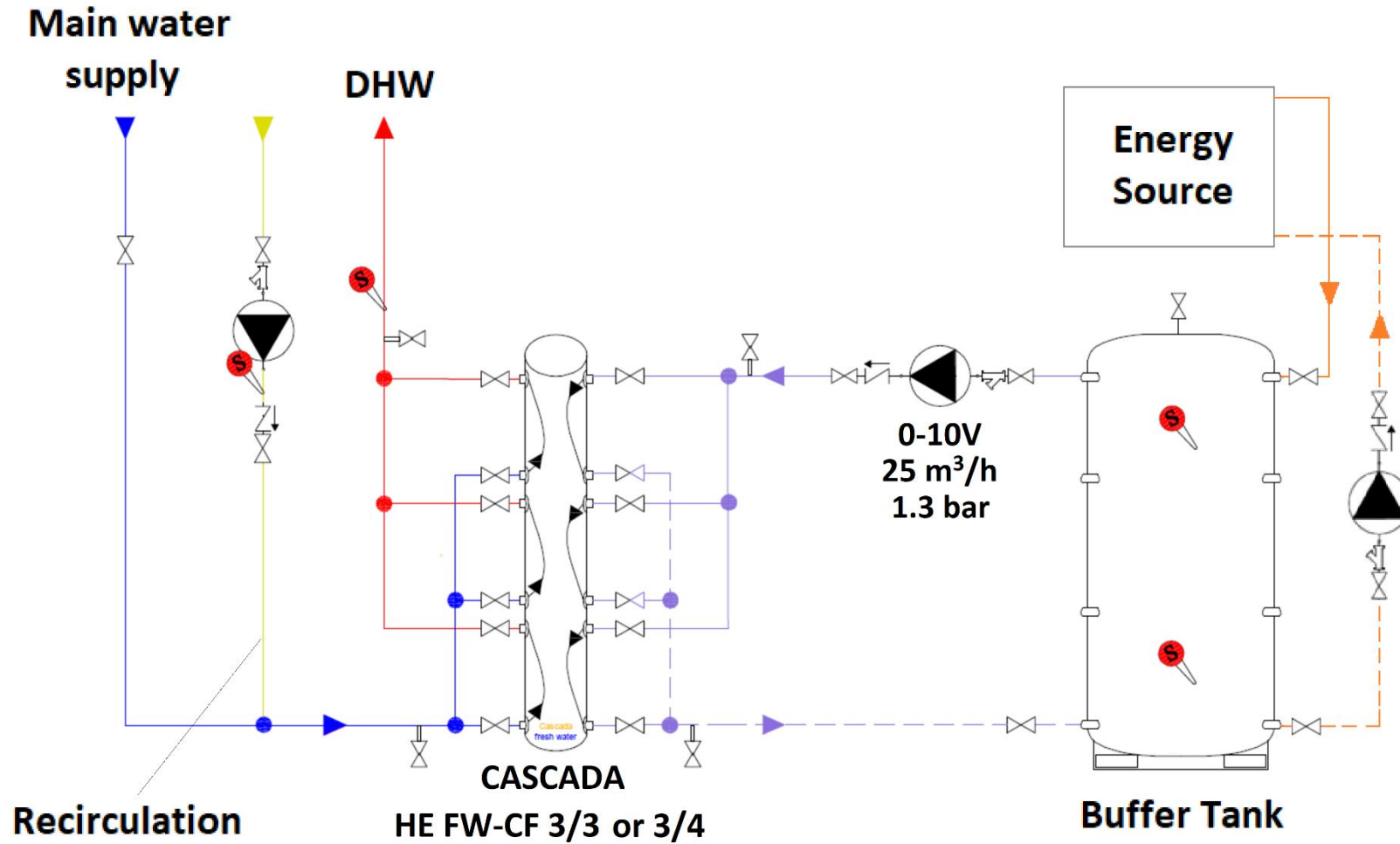



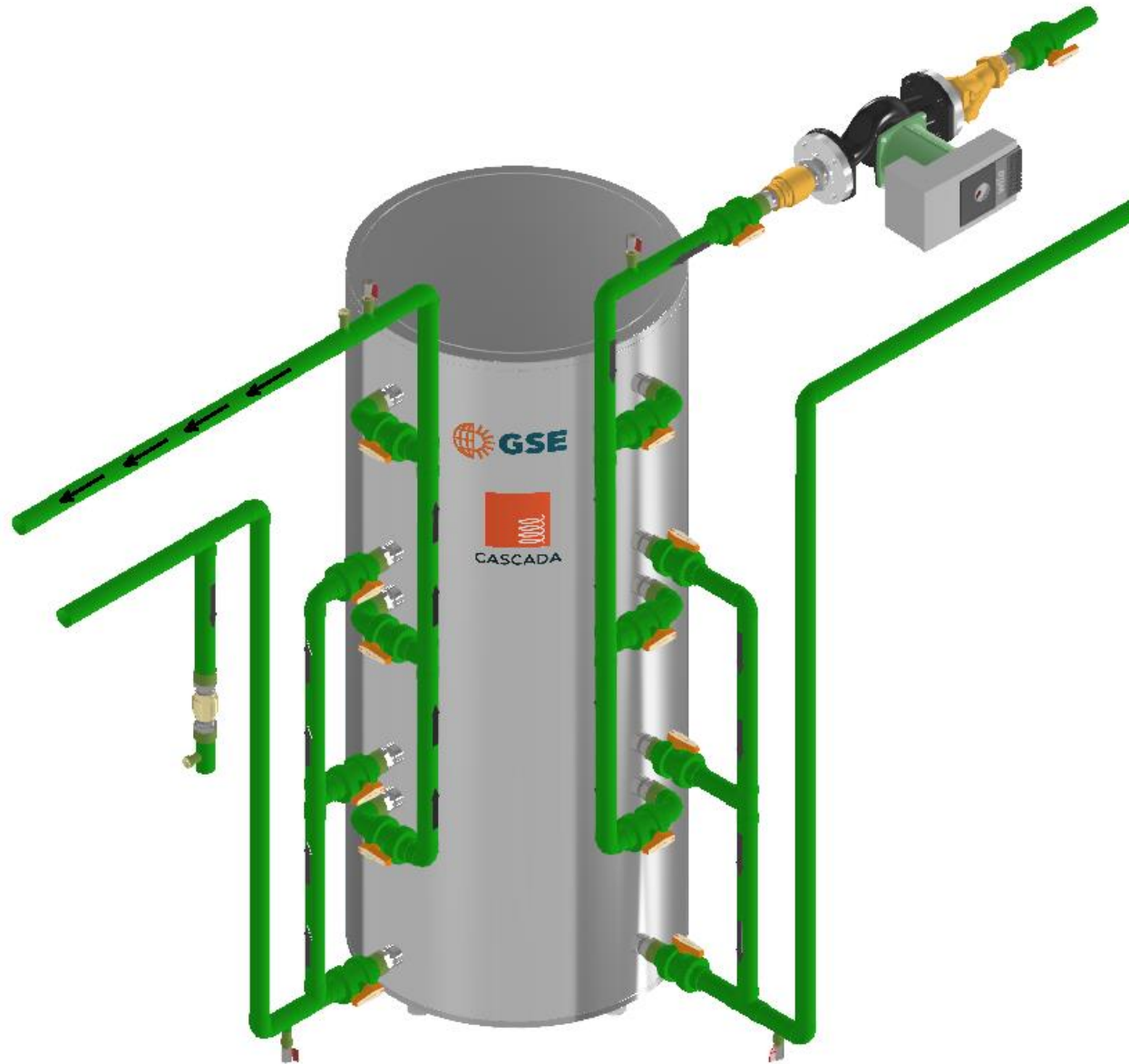

# AUTOMATION CONTROL SYSTEM THALES AK400 FUNCTIONS



FUNCTIONS	Default	Potential
Control and operation via integrated 4.3" touch screen	✓	
Visualize system operations in real time	✓	
Domestic hot water temperature control (set point 1, time-schedule)	✓	
Heat pump control (Remote on/off with time-schedule, tank temperature adjustment set point 2)	✓	
Boiler control (built-in relay with time-schedule, tank temperature adjustment set point 3)	✓	
Variable speed water pump control (PWM/0-10V) for energy transfer	✓	
Control of a second variable speed water pump (PWM/0-10V) for energy transfer		✓
Solar Field Control with Variable Speed Water Pump (PWM/0-10V)		✓
Future firmware upgrades		✓

# TEMPERATURE AND PRESSURE DROP CHARTS

## Example of calculating required primary circuit temperature

Suppose the supply we need is 25 lt/min. For the production of 45°C Domestic Hot Water (DHW) and a supply of 25 lt/min (see Figure 1), going vertically downwards we see that the required temperature in the primary circuit must be at least 46.7°C (see Figure 1).

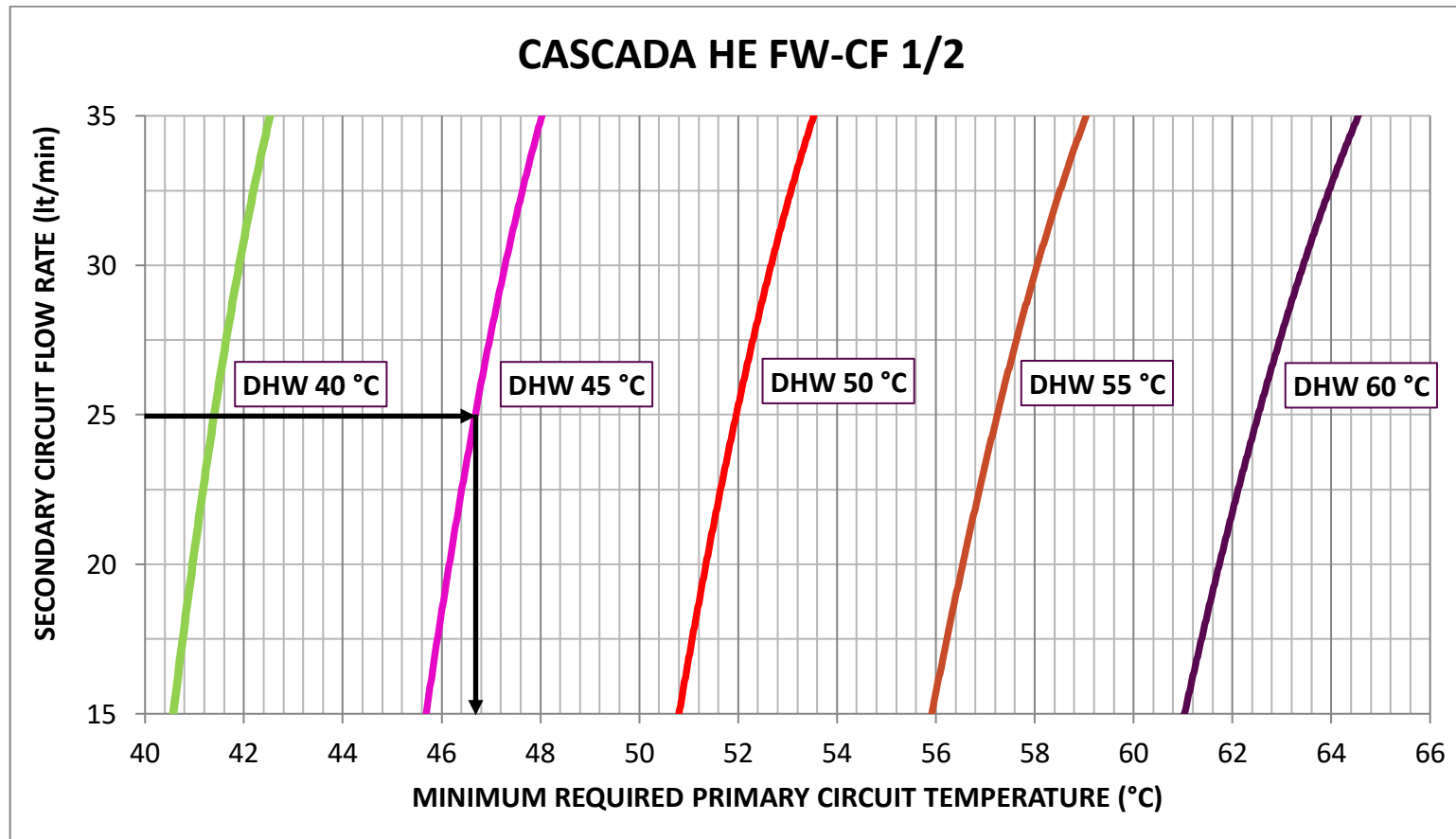
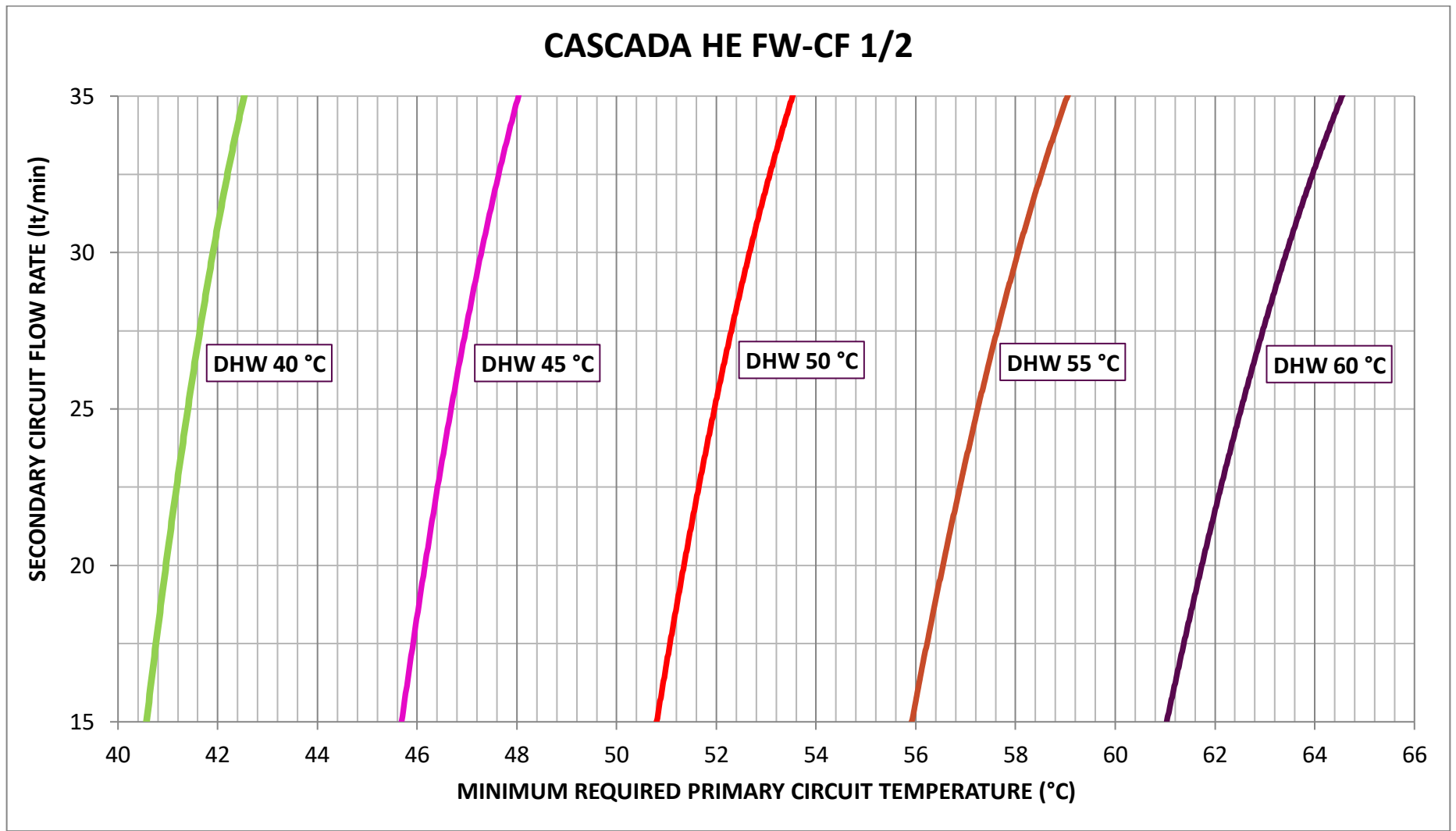
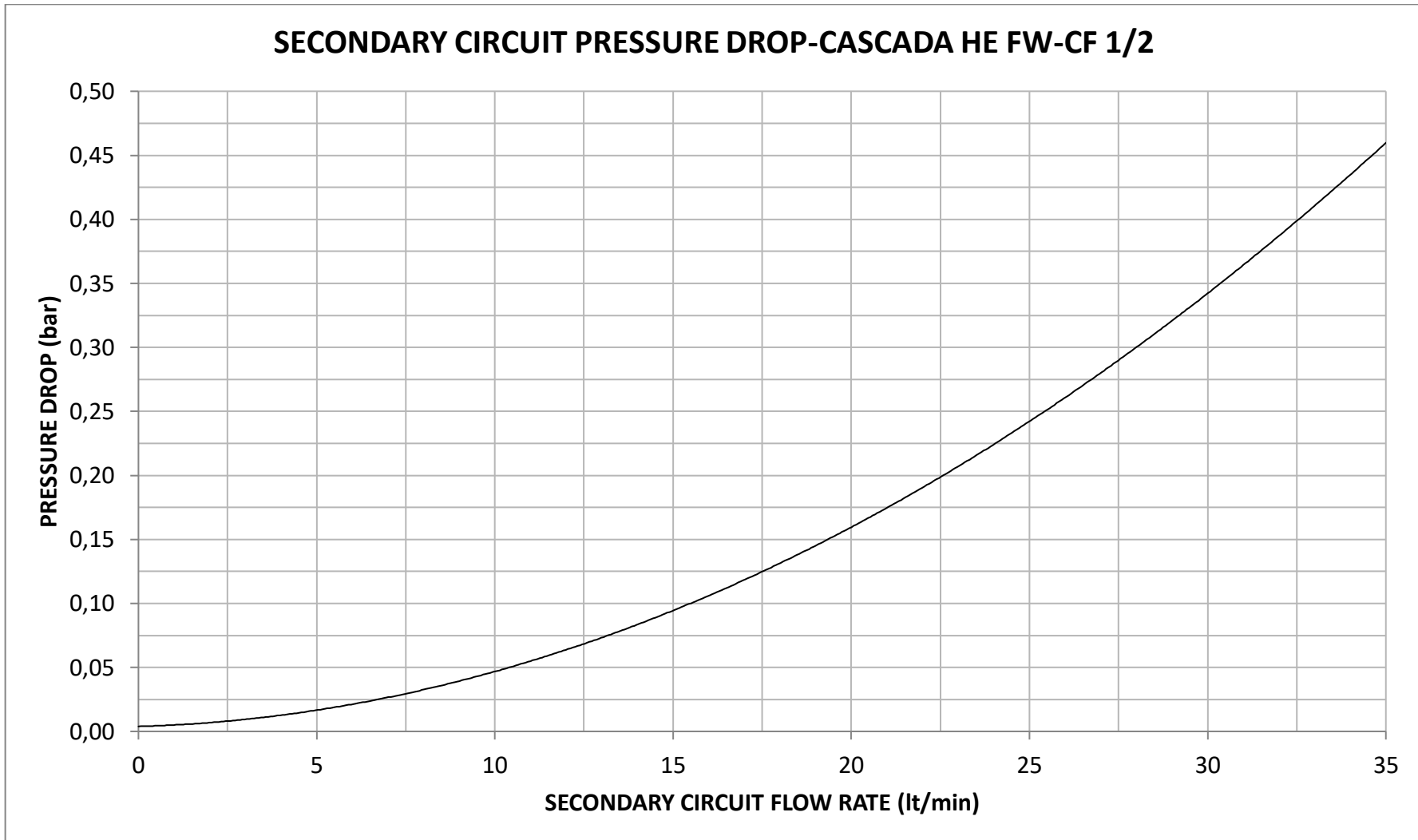

Figure 1

# 1) CASCADA HE FW-CF 1/2



i) Minimum required primary circuit temperature as a function of the secondary circuit flow rate and the desired DHW temperature



ii) Secondary circuit (DHW) pressure drop diagram

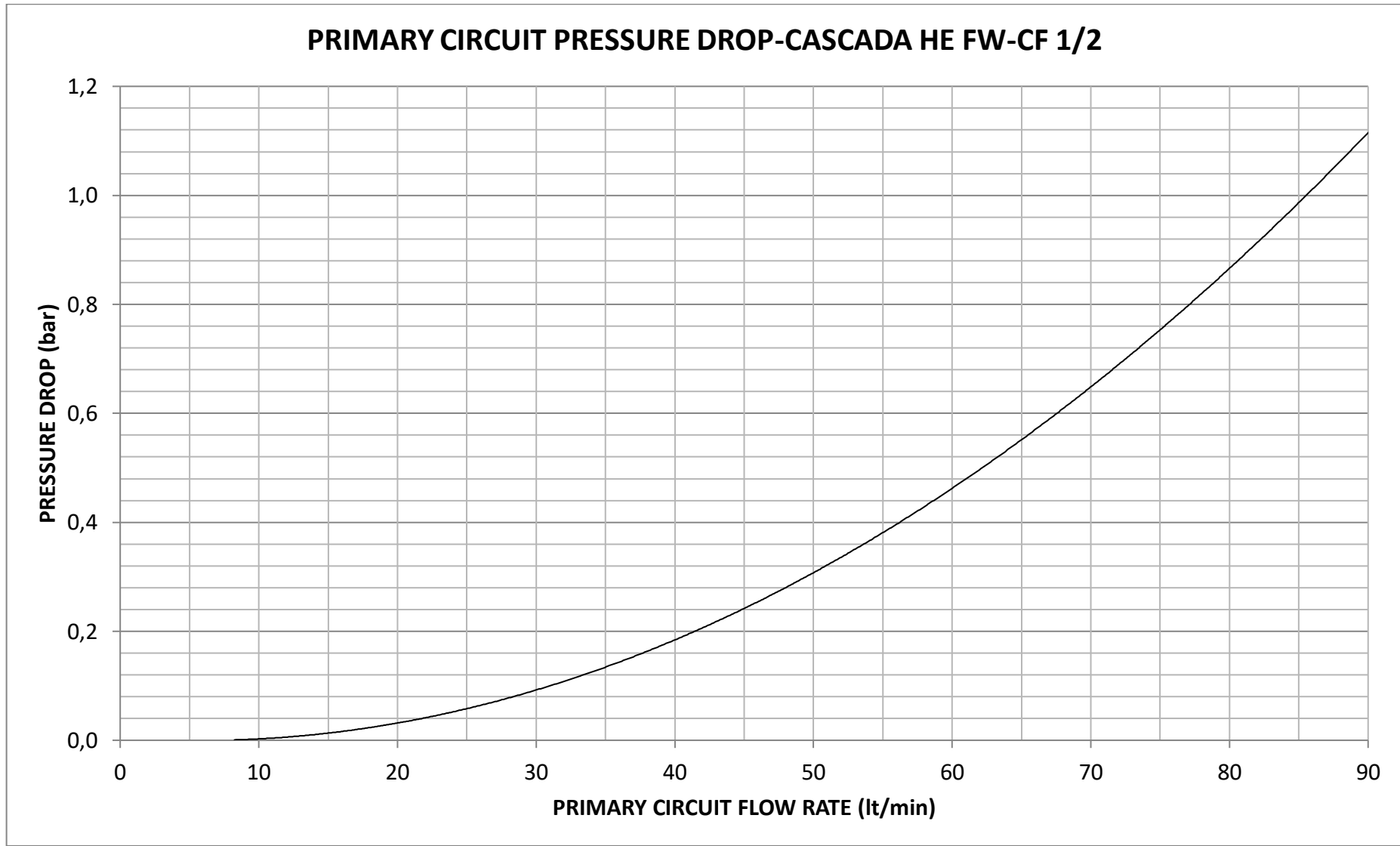

iii) Primary circuit pressure drop diagram

## 2) CASCADA HE FW-CF 2/2

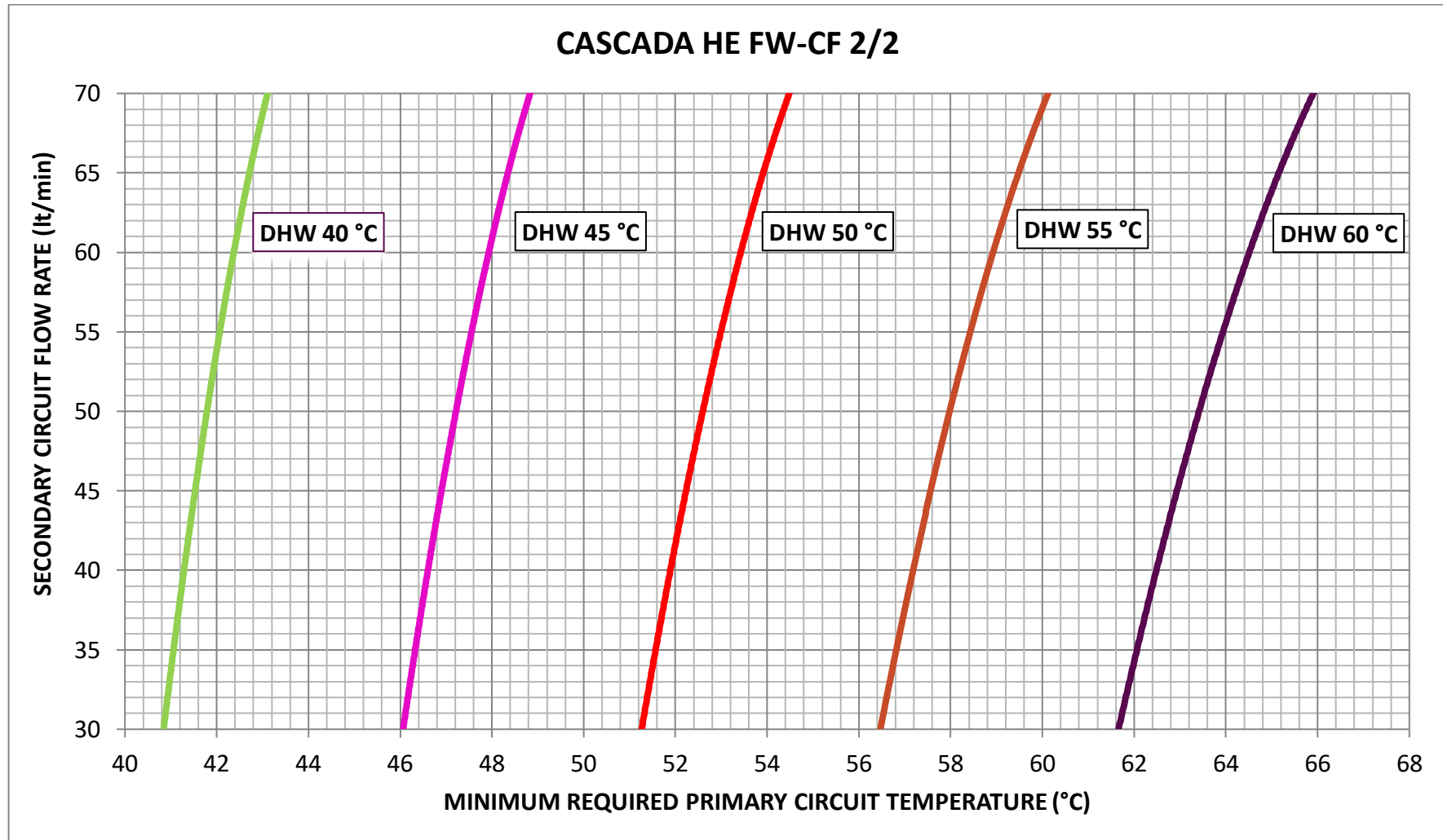

i) Minimum required primary circuit temperature as a function of the secondary circuit flow rate and the desired DHW temperature

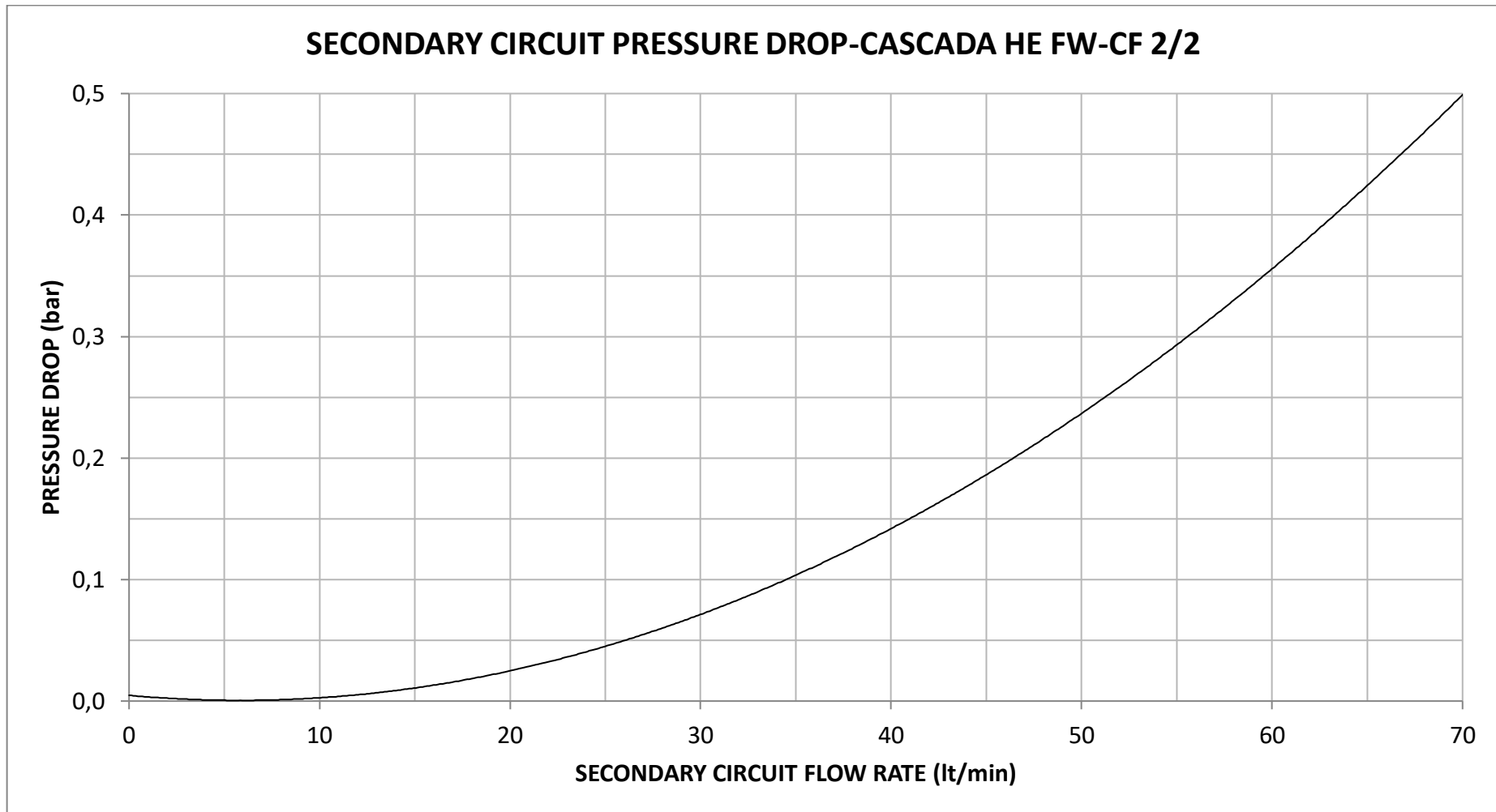

ii) Secondary circuit (DHW) pressure drop diagram



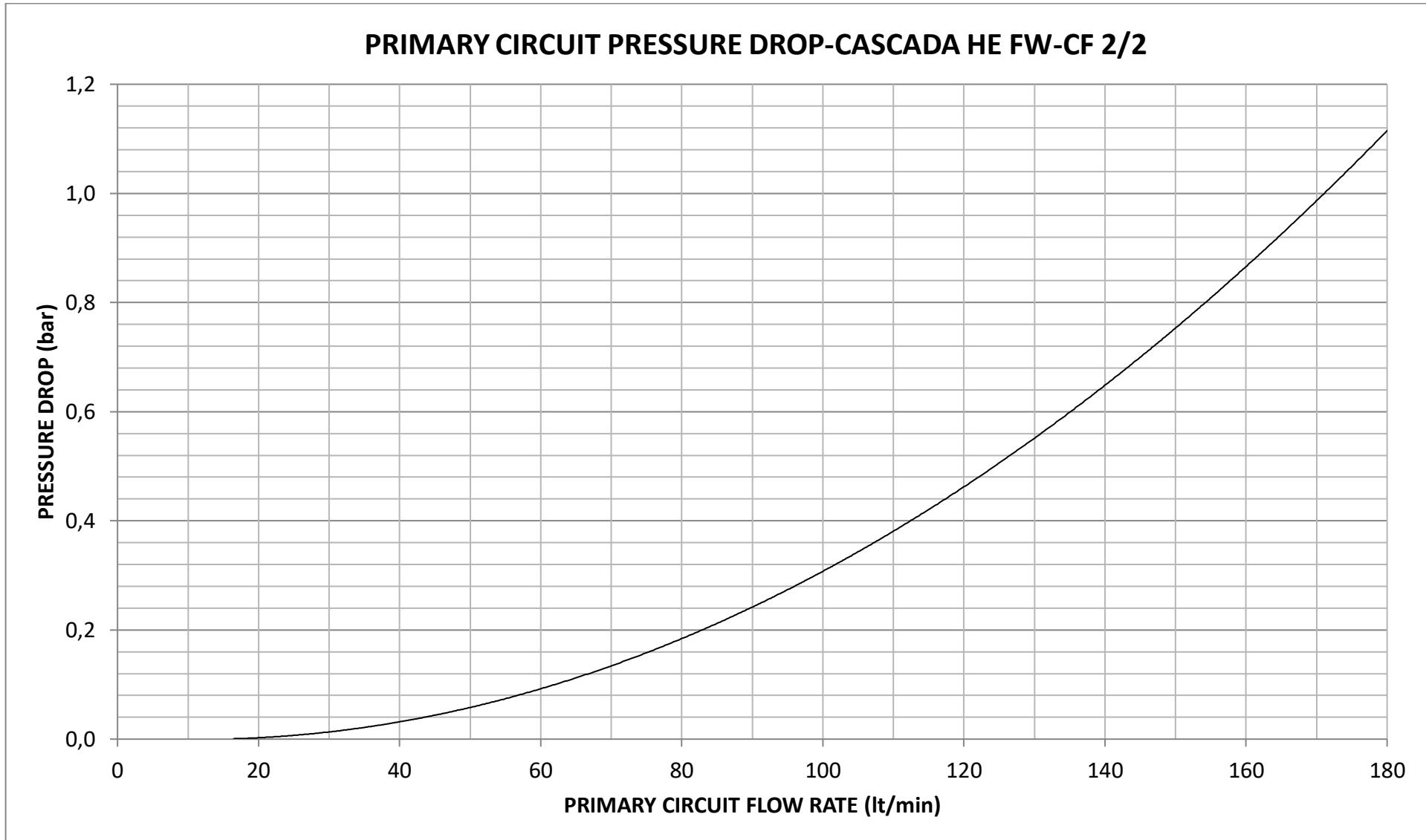

iii) Primary circuit pressure drop diagram

### 3) CASCADA HE FW-CF 1/3

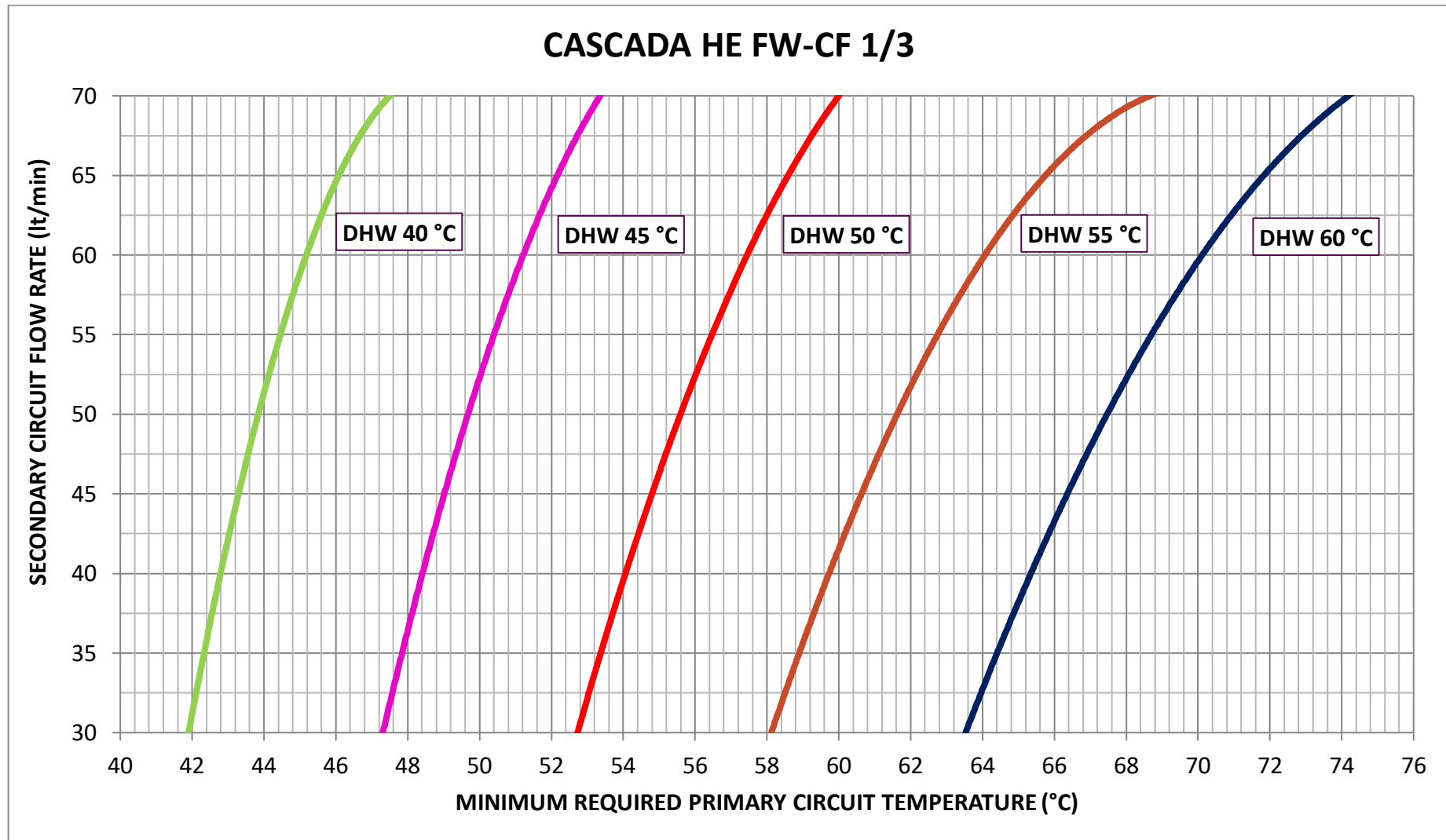

i) Minimum required primary circuit temperature as a function of the secondary circuit flow rate and the desired DHW temperature

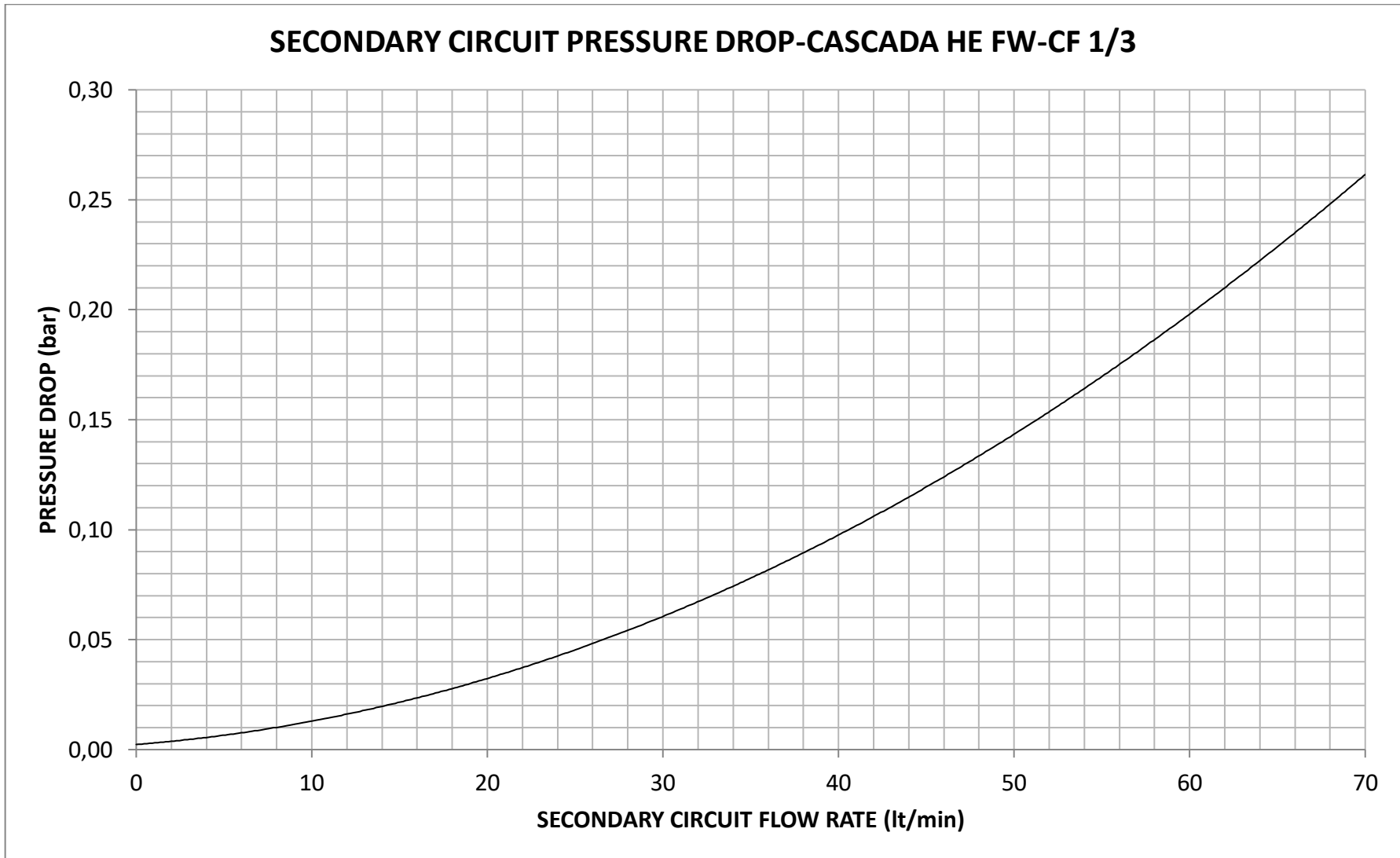

ii) Secondary circuit (DHW) pressure drop diagram

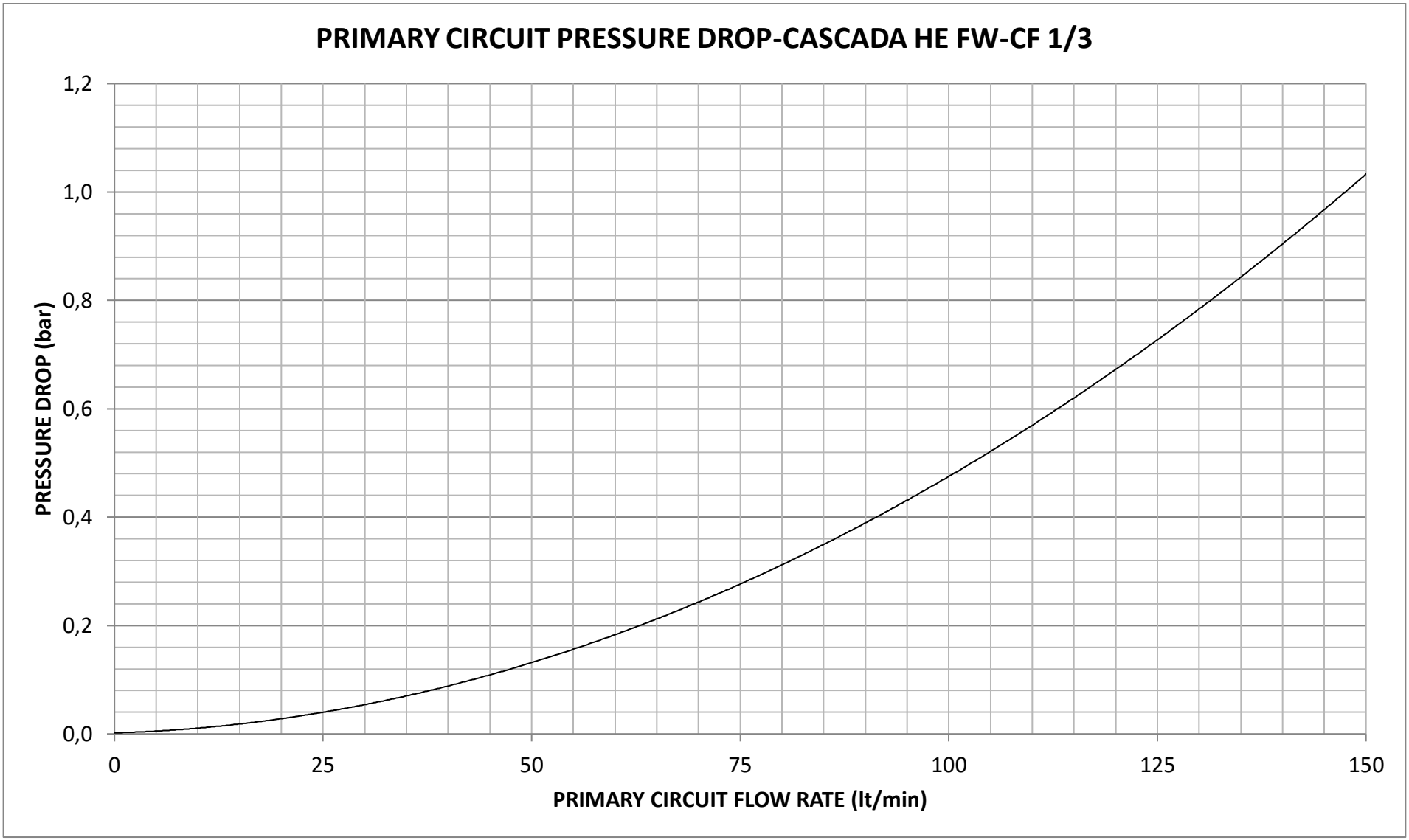

iii) Primary circuit pressure drop diagram

#### 4) CASCADA HE FW-CF 2/3

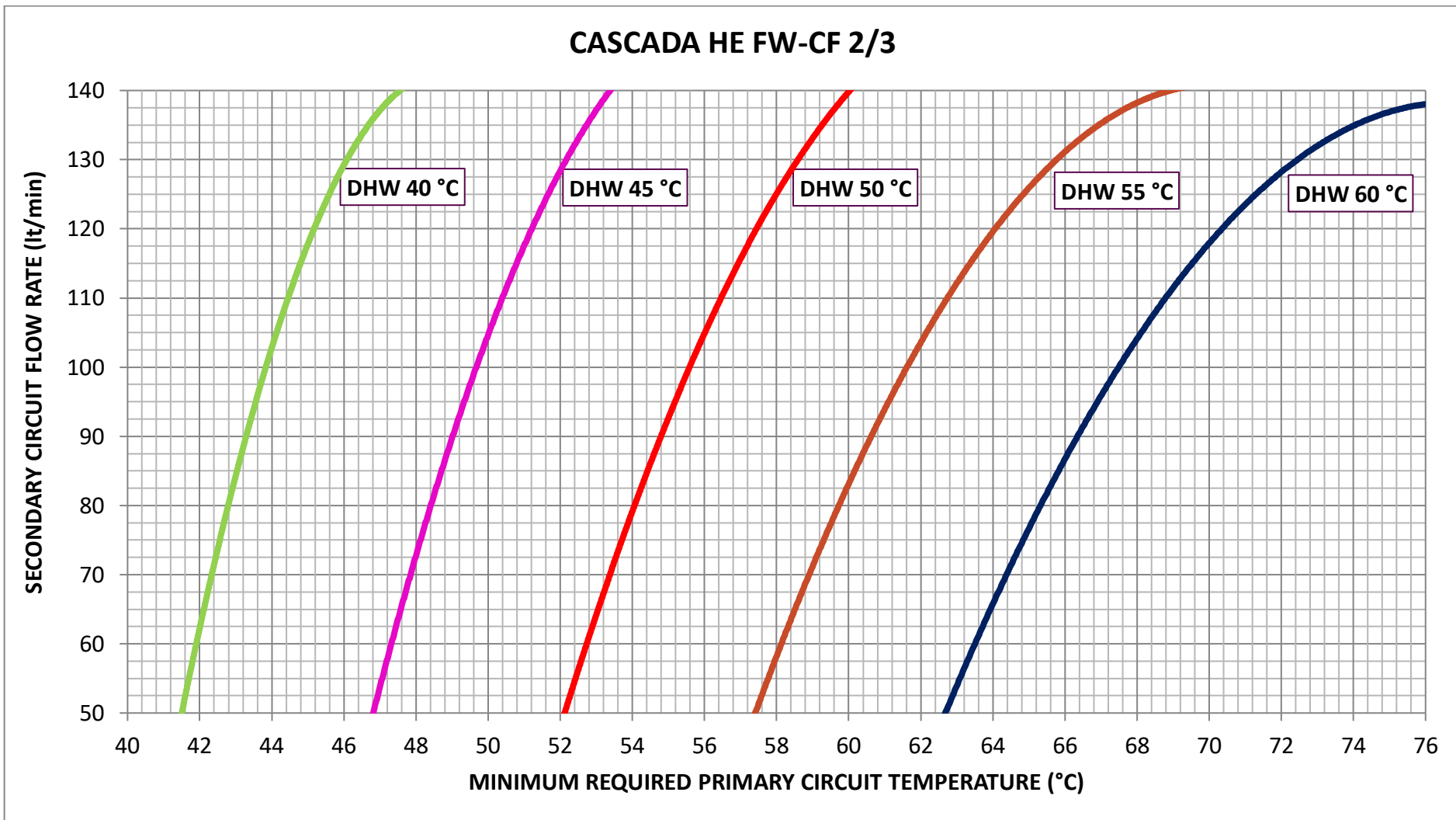

i) Minimum required primary circuit temperature as a function of the secondary circuit flow rate and the desired DHW temperature

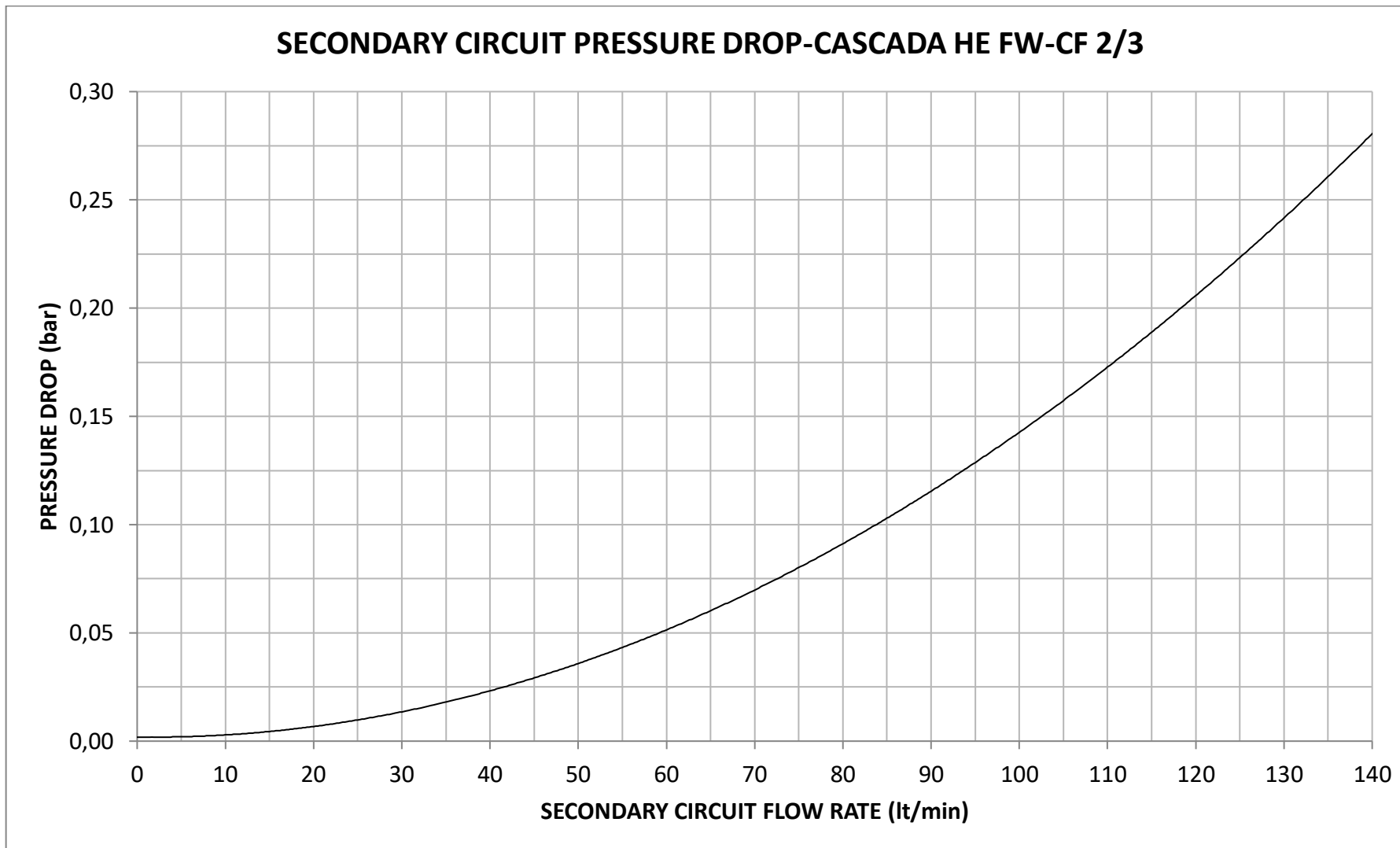

ii) Secondary circuit (DHW) pressure drop diagram

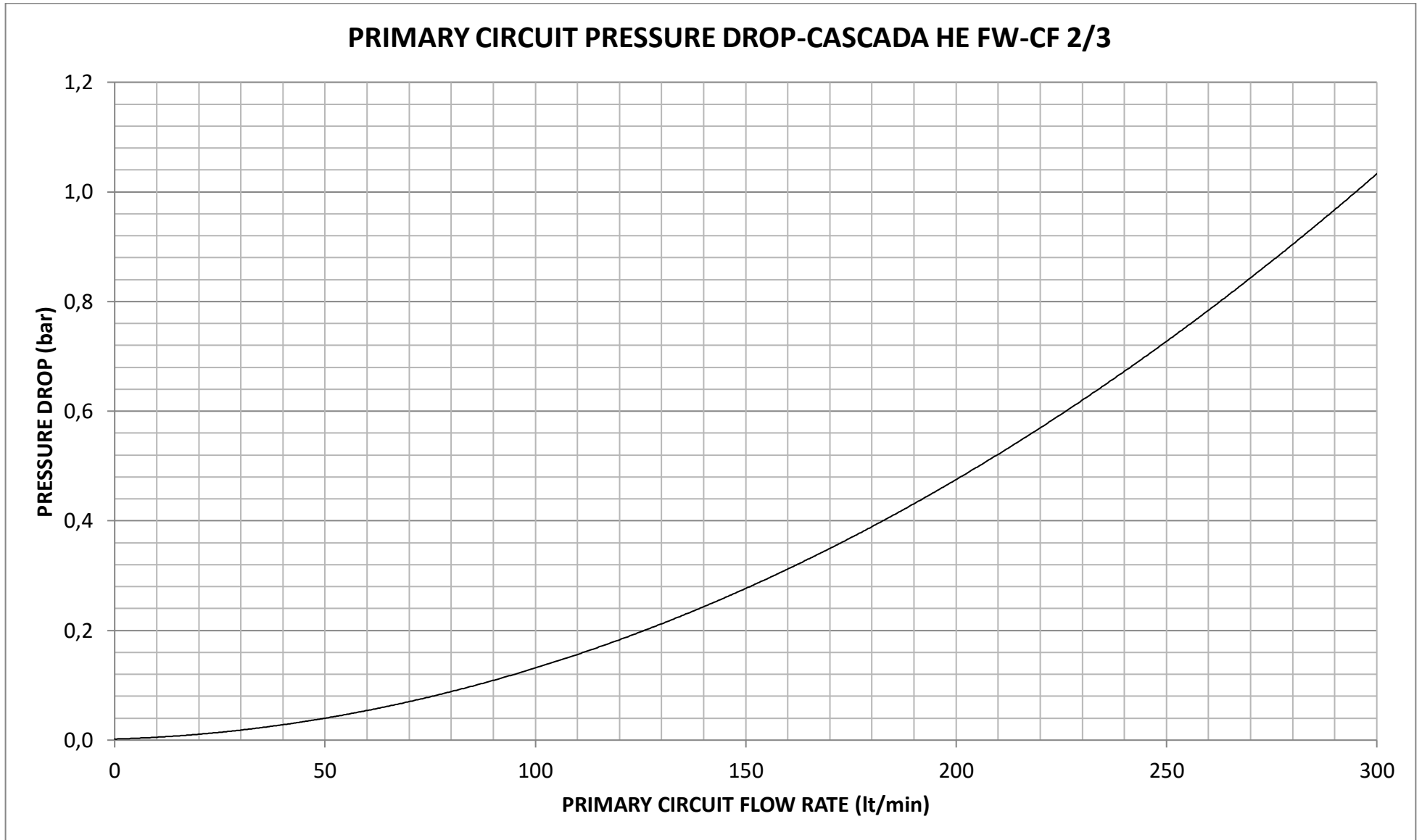

iii) Primary circuit pressure drop diagram

## 5) CASCADA HE FW-CF 3/3

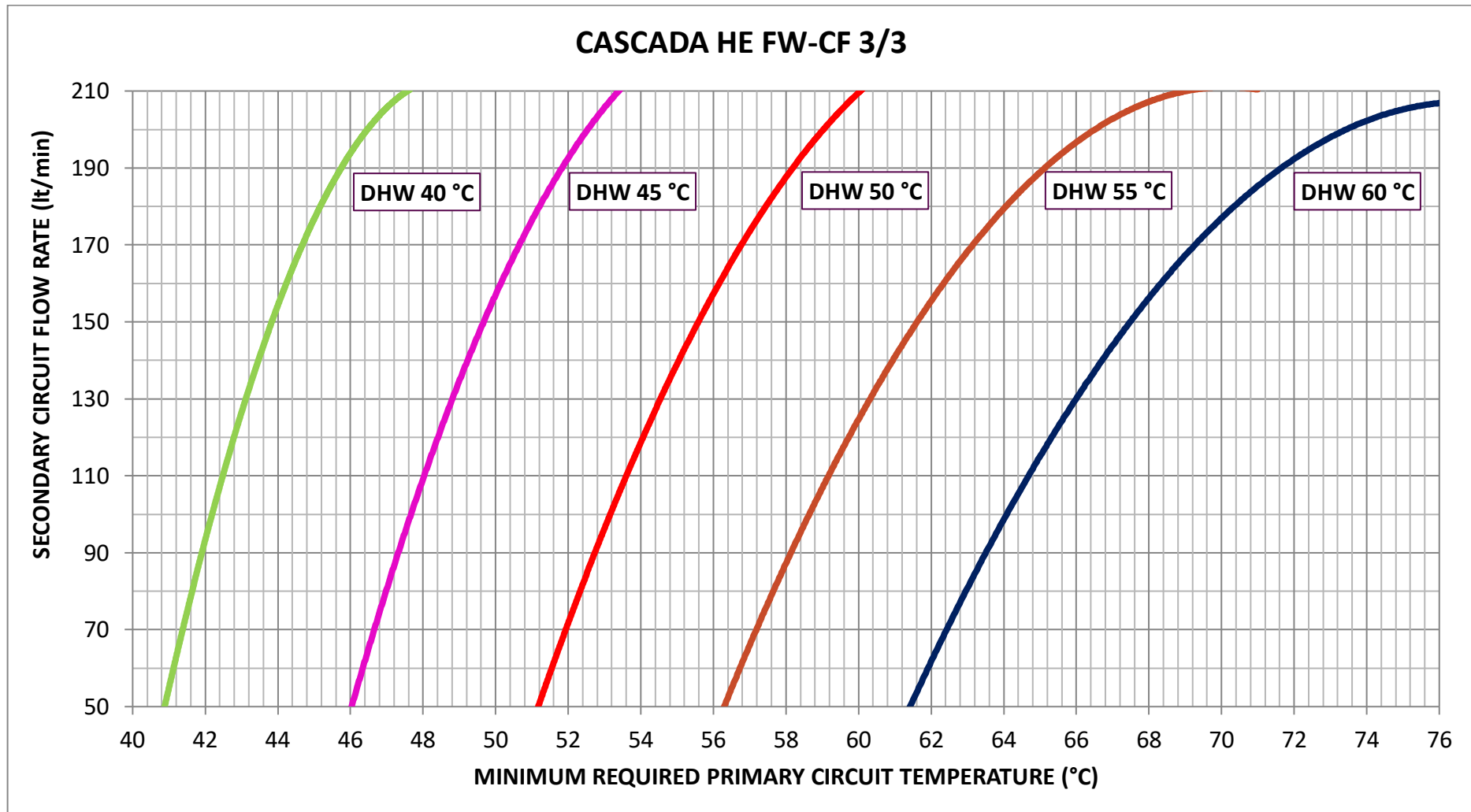

i) Minimum required primary circuit temperature as a function of the secondary circuit flow rate and the desired DHW temperature



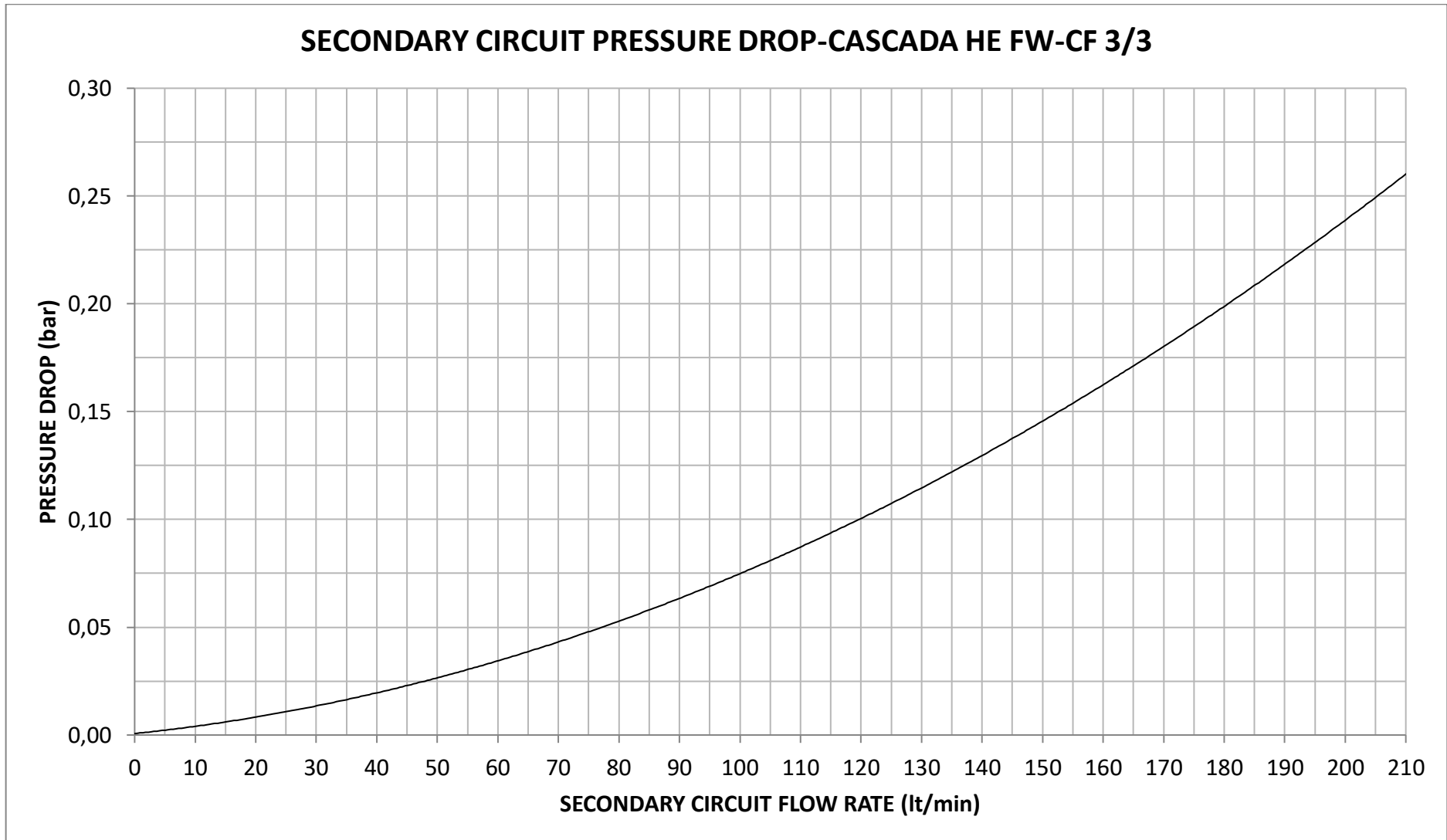

ii) Secondary circuit (DHW) pressure drop diagram

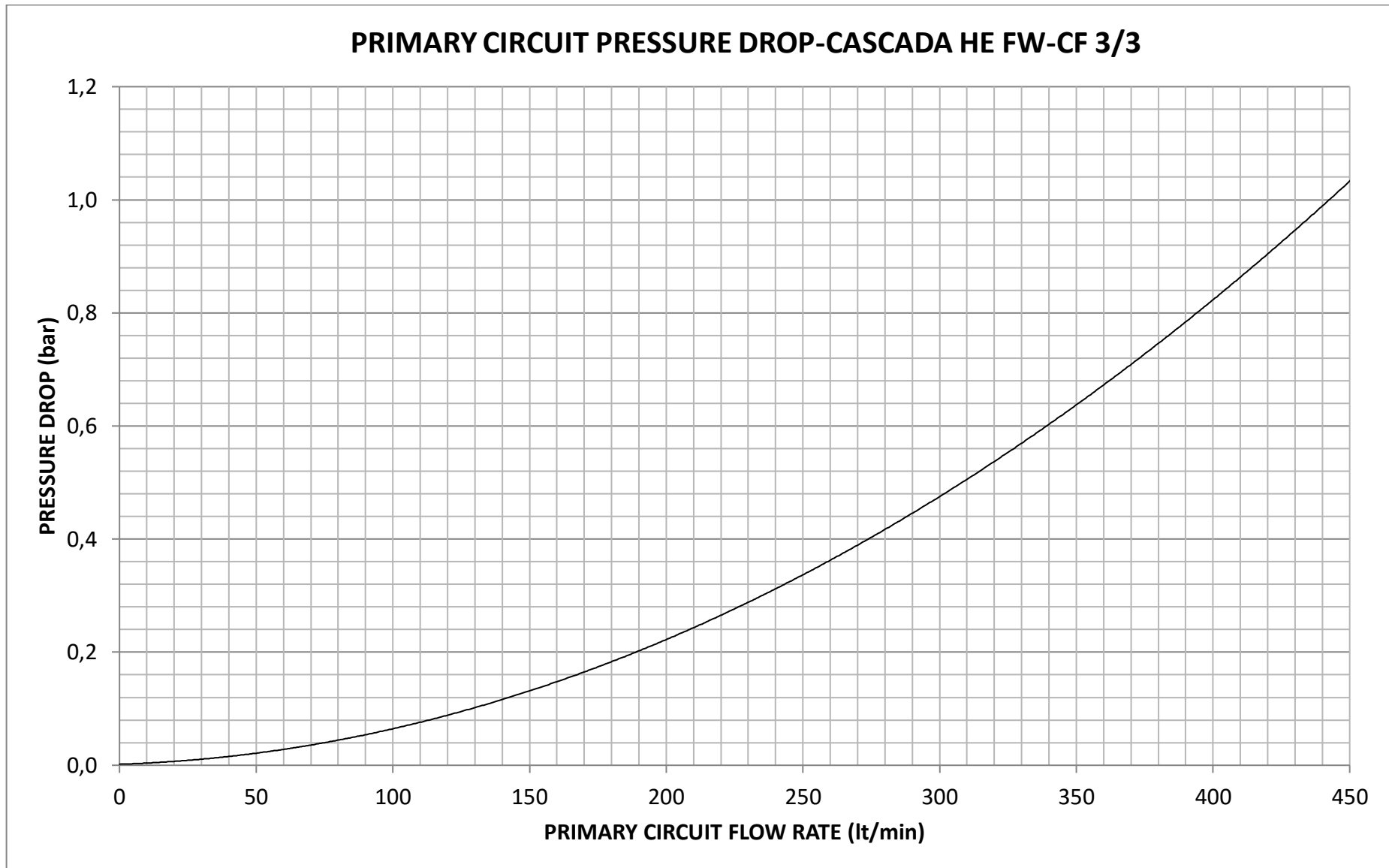

iii) Primary circuit pressure drop diagram